

MLCI & BEAD PARTS NUMBER CODE (HOW TO ORDER)

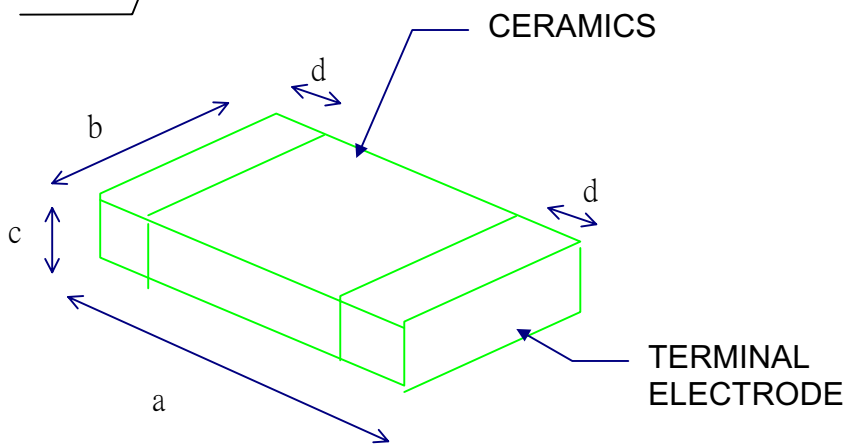
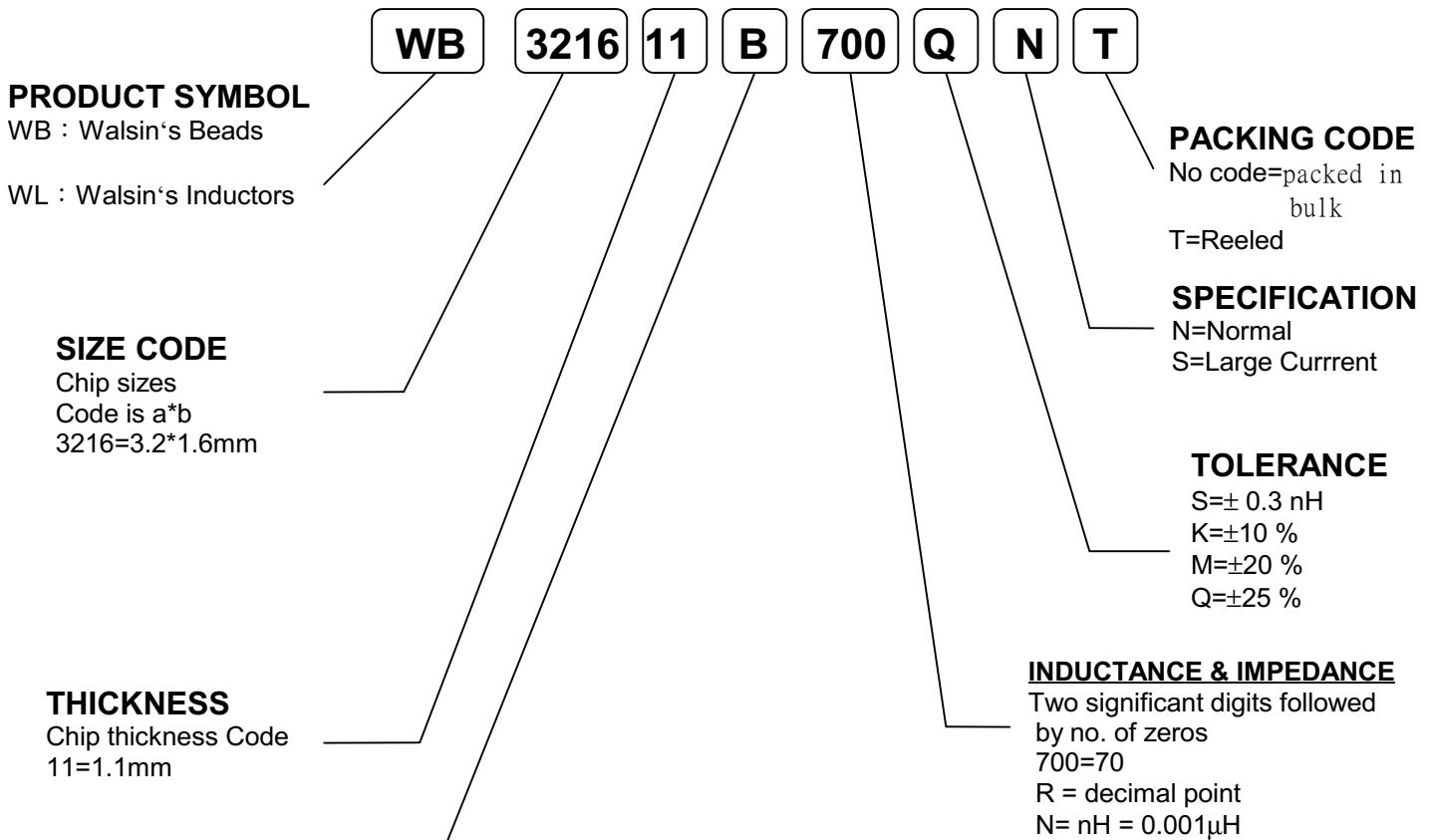

TYPICAL MATERIAL CHARACTERISTICS

Material Code	A	B	C	D	F	H	L
Initial Permeability	1200	500	220	120	60	25	1
Curie Temperature	>120	>120	>130	>150	>170	>200	-
Density(g/cm ³)	>4.9	>4.9	>4.9	>4.9	>4.9	>4.9	2.6
Dielectric Constant	-	-	-	-	-	-	6